

tipa®

"Since 1950..."

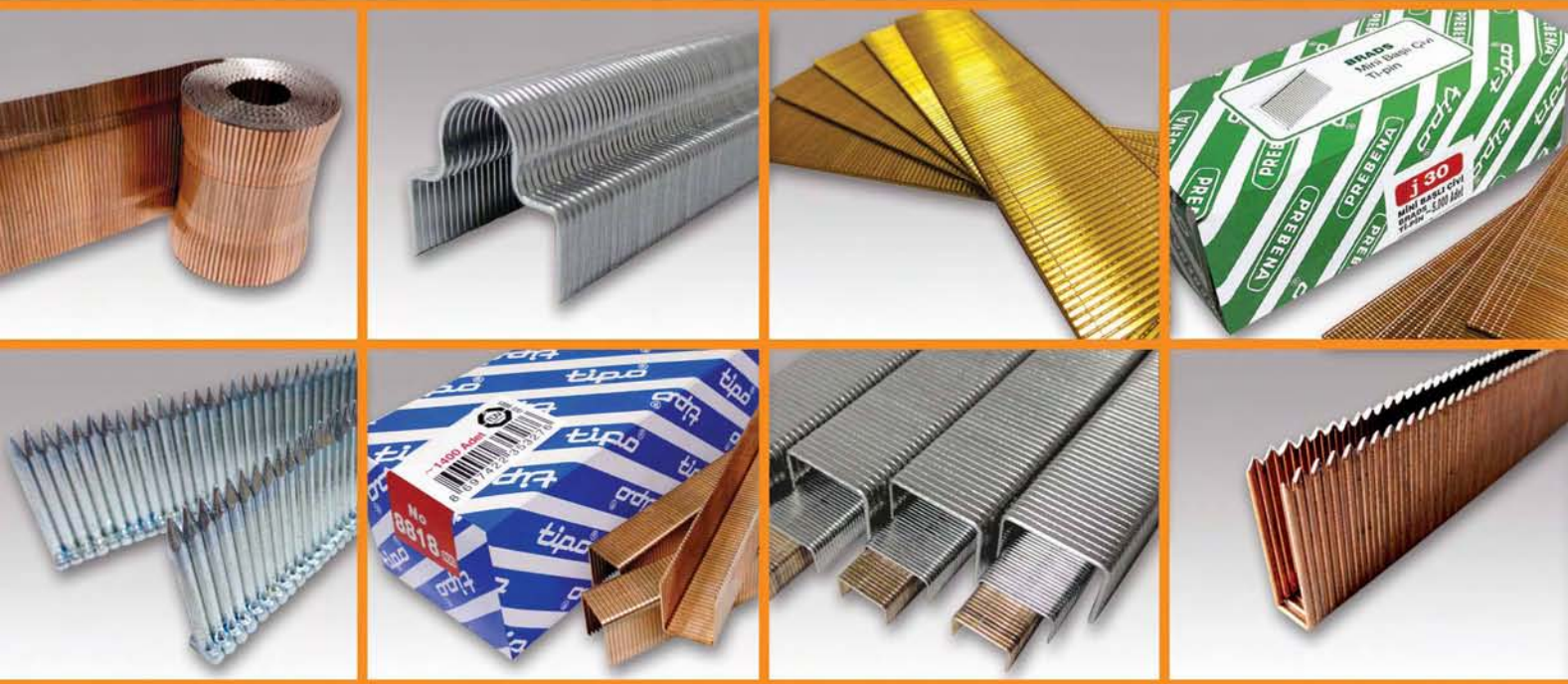

www.tipotel.com
İZMİR



ABOUT US

Our staple production history starts at 1950s with our founder M. Tacettin ERSOY's visit to Drupa show. Staples which were only imported then, now being manufactured in our factory over 7500m sq. land, in Gaziemir, İzmir, Turkey with modern production processes. Now our factory is capable of manufacturing more than 150 different staples with the advantage of a deep know-how since 1950.

A leading company of this business, Tipso is proud to be the first manufacturers of some staple types in our country. The first producer of loop (ring) staples, brads, roll carton closing staples, stainless steel staples (inox staples), etc... Today with the capability of hundreds of different staples, modern production machines & tools and continuous investments, our company is laying the strong foundations of the tomorrows and enlightening the future.

HISTORY

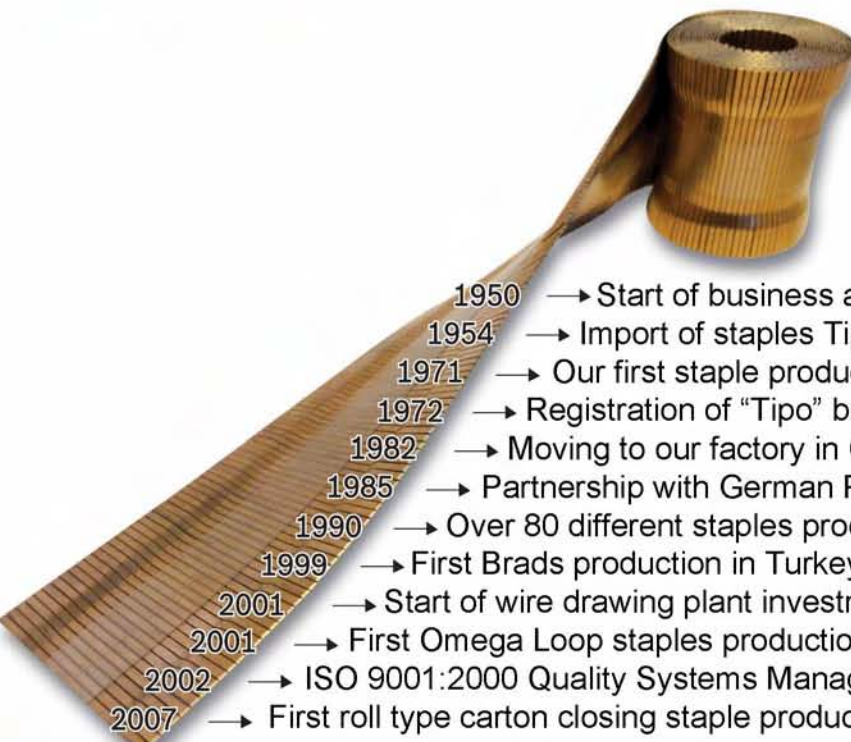

- 1950 → Start of business as Tipso Printing Supplies
- 1954 → Import of staples Tipso Import & Export Co.
- 1971 → Our first staple production machine import from Germany
- 1972 → Registration of "Tipso" brand
- 1982 → Moving to our factory in Gaziemir as Tipso Tel Ltd.
- 1985 → Partnership with German Prebena brand
- 1990 → Over 80 different staples production in 40th anniversary
- 1999 → First Brads production in Turkey
- 2001 → Start of wire drawing plant investment
- 2001 → First Omega Loop staples production in Turkey
- 2002 → ISO 9001:2000 Quality Systems Management Certificate
- 2007 → First roll type carton closing staple production in Turkey



OUR VISION

To remain as the best of the Turkey and to become a world-wide brand, in all of the products we manufacture and the service we provide.

A Reminiscence of our foundation
"1950"

Hand operated printing machine

OUR MISSION

-To satisfy our customers with reliance of our products and our high level of business ethics.

-Raising the customer satisfaction to highest level possible, by means of manufacturing products with high standards and best quality.



PREBENA 1M-A16-S30

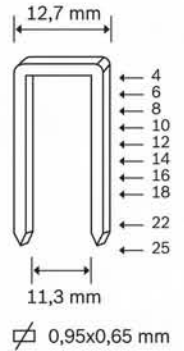

FIELDS OF APPLICATION

- Upholstery
- Fur making
- Shoe making
- Furniture ind.
- Carpet and floor covering
- Nylon, paper and material covering of chests and coffers etc

Available Materials: Copper coated, electro galvanized, Stainless Steel (Inox)

Suitable With: PREBENA-1 M-A16/S30, BEA-380, OMER-80.16, KL ZT8016, ATRO-8 (80), BOSTICH-86/AZ33, KOCAMAZ-KT 50-51-25, SENCO-AT, HAUBOLD-800, DUO-FAST 80, KIHLEBERG: 680



Zimba Teli Staple	804	805	806	808	810	812	814	816	818	822	825
Kutuda Adet Pcs / Box	4500	5000	5000	5000	4000	3000	3000	2750	2500	2000	1500
Kolide Adet Boxes/Carton	50	50	40	30	30	30	30	30	30	30	50

900 (92) SERIES



PREBENA 3M-H40

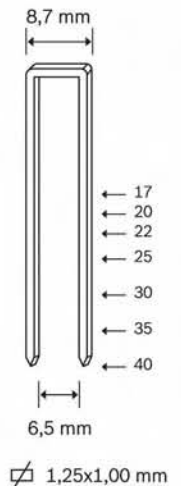

FIELDS OF APPLICATION

- Furniture framework building
- Pallet, wooden box, chest etc. making
- Installation and manufacturing of windows, doors, fixing insulation materials
- At shipyards during boat and yacht manufacturing (Stainless Steel Types)
- Chisel and divergent point types make it harder to pull back staple

Available Materials: Copper coated, electro galvanized, Stainless Steel (Inox)

Suitable With: PREBENA:3 M-H 40, BEA-92, OMER-92, ATRO-92, BOSTICH-SL 5035, KOCAMAZ-KT 92, KIHLEBERG: 664, DUO FAST 92

Zimba Teli Staple	917	920	922	925	930	935	940
Kutuda Adet Pcs / Box	2000	1080	900	900	720	540	600
Kolide Adet Boxes/Carton	50	36	66	36	36	36	36



400 (100) SERIES

tipo®

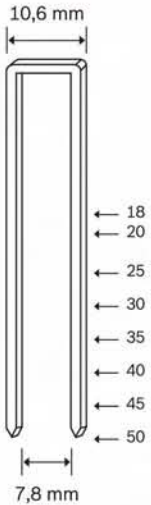

1,52x1,33 mm



PREBENA 5X-L50

FIELDS OF APPLICATION

- In furniture industry, framework fixing and wooden construction
- Wooden box, chest, pallet manufacturing
- Frame making
- Every kind of wooden connection
- Chisel point types make it harder to pull back staple

Available Materials: Copper coated, electro galvanized

Suitable With: PREBENA-5 X-L 50, BEA-14,155 , OMER-M1, M2, ATRO-100, BOSTICH-85/B100, KOCAMAZ-KT 100, KIHLEBERG: 783, SENCO-SNS41

Zimba Teli Staple	420	425	430	435	440	450	455	460
Kutuda Adet Pcs / Box	675	600	525	450	375	300	2000	2000
Kolide Adet Boxes/Carton	36	36	36	36	36	36	14	14

8800 (P88) SERIES

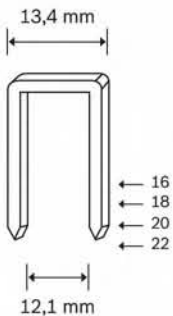

1,15x0,55 mm



FIELDS OF APPLICATION

- Mattress production
- To fix felts and foams
- Stitching boxes, by folding backs.
- In other places where staple ends need to be folded
- Chisel point staples makes easier penetration

Available Materials: Copper coated

Suitable With: PREBENA-PD-S1, KOCAMAZ-KT 88, OMER-PL.88, SENCO-F75, BOSTICH-SB5019

Zimba Teli Staple	8812	8816	8818	8822
Kutuda Adet Pcs / Box	1400	1400	1400	1400
Kolide Adet Boxes/Carton	72	66	36	54



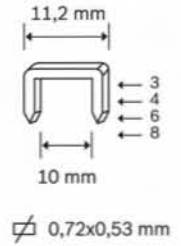

PREBENA HT-VX08

FIELDS OF APPLICATION

- For use with mechanical hand type staplers
- Furniture upholstery
- Automobile upholstery works
- Nylon, paper and material covering of chests
- Packaging works

- Decoration duties
- Fraweworks
- Display cabinets

Available Materials: Copper coated, electro galvanized

Suitable With: PREBENA VX, OMER:G-23/2, RAPID

Zimba Teli Staple	203	204	206	208
Kutuda Adet Pcs / Box	9000	4750	4750	3800
Kolide Adet Boxes/Carton	54	54	54	54

300 (13) SERIES

(13/4,6,8,10)

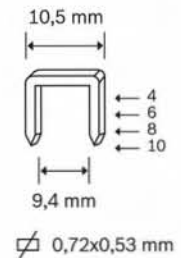

PREBENA HPVZ 08

FIELDS OF APPLICATION

- For use with mechanical hand type staplers
- Furniture upholstery
- Automobile upholstery works
- Nylon, paper and material covering of chests
- Packaging works

- Decoration duties
- Fraweworks
- Display cabinets
- Sign board manufacturing

Available Materials: Copper coated, electro galvanized, Stainless Steel (Inox)

Suitable With: PREBENA TYP-HPVZ 08, OMER:G-23/1, RAPID: R 23, KOCAMAZ-KT 55

Zimba Teli Staple	304	306	308	310
Kutuda Adet Pcs / Box	7000	5000	4000	10000
Kolide Adet Boxes/Carton	54	54	54	32

700 (71) SERIES

tipo[®]

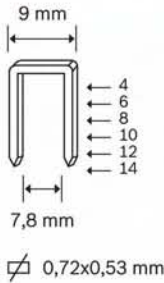

PREBENA 1M-V16

FIELDS OF APPLICATION

- Fur making, leather and fur stretching
- Carpet manufacturing
- Automobile upholstery

Available Materials: Copper coated, Electro galvanized

Suitable With: PREBENA-V, BEA-71, OMER-3G.16, HAUBOLD-7100, DUO-FAST-7, KIHBERG: 670, BOSTICH-SPK3020, ATRO-7

Zimba Teli Staple	704	706	708	710	712	714
Kutuda Adet Pcs / Box	8400	6000	4800	3600	3600	2700
Kolide Adet Boxes/Carton	100	54	54	54	54	54

100 (93) SERIES

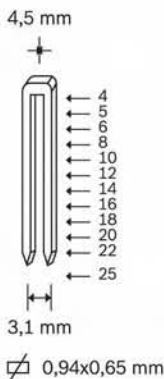

PREBENA 1M-025/SDS

FIELDS OF APPLICATION

- Shoe making industry
- Bamboo furniture manufacturing
- Brush manufacturing
- Ready-to-install & modular kitchen and bathroom manufacturing
- Aluminum and PVC shutter production (4-6mm)
- Cabinet and drawer backs fixing

Available Materials: Electro galvanized, Stainless Steel (Inox)

Suitable With: PREBENA-1 M-025/SDS, BEA-97, OMER-4097, ATRO-93, KOCAMAZ-KT 93-94, HAUBOLD-4000, KIHBERG : 690, DUO-FAST 40

Zimba Teli Staple	104	106	107	108	110	112	114	116	118	120	122	125
Kutuda Adet Pcs / Box	8000	6000	4000	4000	4000	4000	2500	2500	2500	2000	2000	2000
Kolide Adet Boxes/Carton	80	80	80	80	75	65	80	80	70	80	75	65

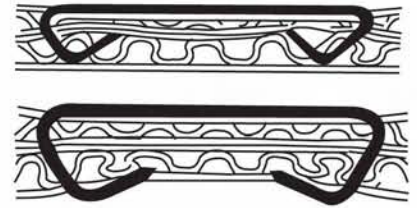
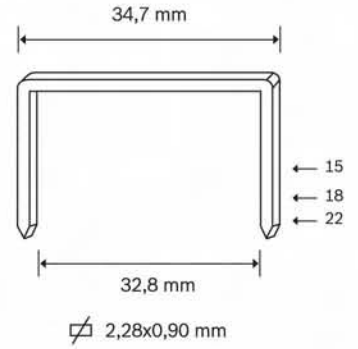

SACA ADB 19/35
KOLİ KAPAMA MAKİNESİ

FIELDS OF APPLICATION

- Carton Closing
- Different staple lengths for different carton thickness

BENEFITS OF CARTON CLOSING WITH STAPLES

- Stapled cartons are stronger
- Bended staple legs provide maximum strength
- Stapled cartons are more durable during transport
- Staples meet the high shipping and handling requirements
- You can close your carton with staples instantly
- With staples it is fast and you can check if the box is closed right-away
- Staples are resistant to temperature and humidity
- Unlike other methods staple closure is unaffected by extremes of temperature and humidity
- Stapling enhance advertising value
- Staples do not cover your sales message, logo or product identification
- Stapling discourages theft
- Stapled cartons provide safe & secure product during delivery
- Staples are environmentally friendly
- Staples can be separated and recycled easily

Available Materials: Copper coated, electro galvanized

Suitable With: SACA-ADB, SACA-RASA, PREBENA-B, BEA-ATA22, OMER-35, ATRO-35, KOCAMAZ-KT 35, KIHLEBERG : 560, SENCO-35

Zimba Teli Staple	615	618	618	622	615	618
Kutuda Adet Pcs / Box	1000	800	1000	1000	10000	8700
Kolide Adet Boxes/Carton	32	28	24	20	1	1

ROLL CARTON CLOSING STAPLES

BENEFITS OF ROLL CARTON CLOSING STAPLES

- Roll carton closing staples help you reduce your costs
- Roll carton closing staples decrease reloading time of staple, increase your production
- There is 1000 pieces of staples in a roll (-5000pcs/roll also available upon request)
- Single loading provides the user to staple 1000 times
- Fast and easy to use
- Saves time on packaging. No wastage of staples, no breakage of strips

Available Materials: Copper coated



SACA RASA-19/35
Roll carton closing stapler



SACA HDCS 19/35
Standart mechanical carton closing stapler

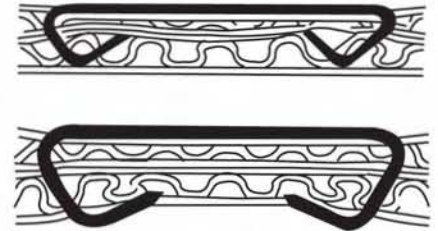

Roll Carton Closing Staples

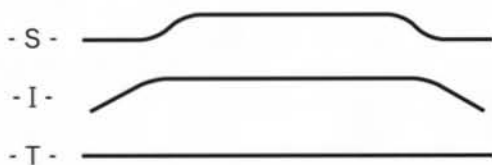

67,7 - 61,2 mm

1,90x0,90 mm

Roll length: 1970 mm

Zimba Teli Staple	S-15	S-18
Kutuda Adet Pcs / Box	1000	1000
Kolide Adet Boxes/Carton	20	20

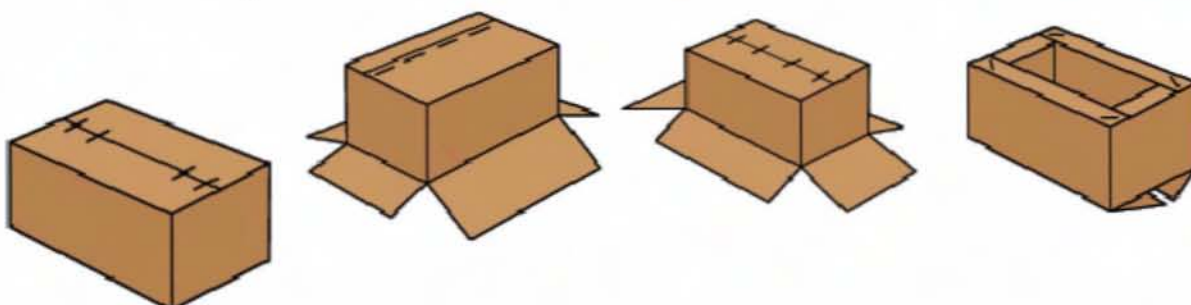
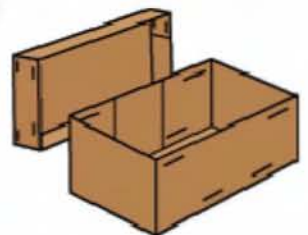



PREBENA 2P-ES40/SDS

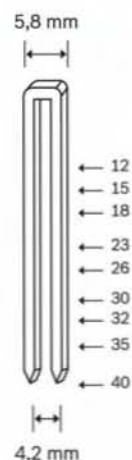

FIELDS OF APPLICATION

- Bamboo manufacturing
- Hard wood flooring
- Furniture and cabinet assembly
- Furniture spring connection

- Aluminum and vinyl outdoor coating
- Drawer, cabinet back production
- Light duty wooden object production
- For use with some combi tools with brads

Available Materials: Electro galvanized

Suitable With: PREBENA 2P-ES40SDS

Zimba Teli Staple	6026	6030	6035	6040
Kutuda Adet Pcs / Box	1920	1600	1600	1600
Kolide Adet Boxes/Carton	54	60	54	48



PREBENA 3M-E50 PR

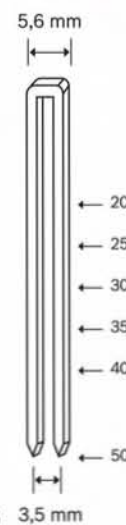

FIELDS OF APPLICATION

- Bamboo manufacturing
- Hard wood flooring
- Furniture and cabinet assembly
- Furniture spring connection

- Aluminum and vinyl outdoor coating
- Drawer, cabinet back production
- Light duty wooden object production
- For use with some combi tools with brads

Available Materials: Electro galvanized

Suitable With: PREBENA 3M-E50 PR, BEA-90, OMER-90.16, ATRO-90, BOSTICH-SX5035, KLZT 9040, KIHLEBERG: 781, DUO-FAST 18, HAUBOLD-6000, SENCO-L

Zimba Teli Staple	9015	9020	9025	9030	9035	9040	9050
Kutuda Adet Pcs / Box	1400	1400	1400	1400	1400	1400	1400
Kolide Adet Boxes/Carton	72	60	40	40	48	42	32

T HEAD NAIL

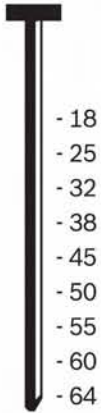

2,2 mm



PREBENA 5X-T65

FIELDS OF APPLICATION

- Wood to metal connections in furnitures
- Wood to concrete in house building
- Extra strong steel nails for hard surfaces

Available Materials: Electro galvanized high carbon steel



Suitable With: PREBENA 5 XT-65, BEA-T54, OMER-TN.32, TN.50



Zimba Teli Staple	ST18	ST25	ST32	ST38	ST45	ST50	ST55	ST60	ST64
Kutuda Adet Pcs / Box	2000	2000	2000	1000	1000	1000	1000	1000	1000
Kolide Adet Boxes/Carton	10	10	10	10	10	10	10	10	10



PREBENA 2P-J50 SDS

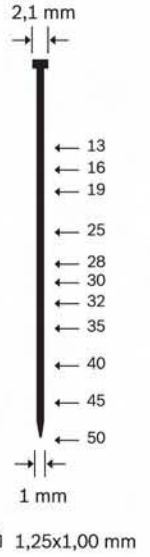

1,25x1,00 mm

FIELDS OF APPLICATION

- Wooden, MDF, bamboo production
- Frames of mirrors, pictures, windows
- To fix before gluing
- Flooring side works
- Floor covering
- Shoe manufacturing

- Fixing of decorative wooden panels
- For invisible fastening
- In applications instead of nails
- Stainless steel when needed

Available Materials: Electro galvanized, Stainless Steel (Inox)

Suitable With: PREBENA 2P-J50-SDS, BEA-SK300, OMER-12, ATRO-TIPIN, BOSTICH-BT1300, SENCO: AX (LS2), KOCAMAZ-KT 30-KT 40, KLZT F32, DUO-FAST-B44, HAUBOLD-SKN12, KIHBERG : 512

Zimba Teli Staple	J13	J16	J19	J25	J28	J30	J32	J35	J40	J50
Kutuda Adet Pcs / Box	10000	10000	10000	5000	5000	5000	5000	5000	5000	4000
Kolide Adet Boxes/Carton	15	15	15	15	15	15	15	15	15	15

N TYPE (T) BRADS



PREBENA 3C-N65

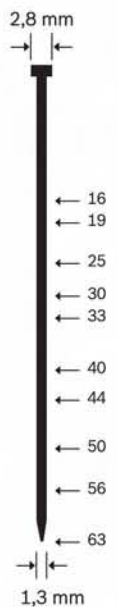

1,65x1,36 mm

FIELDS OF APPLICATION

- Wooden, MDF, bamboo production
- Frameworks of armchair, chair etc.
- Frames of mirrors, pictures, windows
- To fix before gluing

- Fixing of decorative wooden panels
- Flooring side works
- Floor covering
- In applications instead of nails

Available Materials: Electro galvanized

Suitable With: PREBENA 3C-N65, BEA-SK400, OMER-14, ATRO-TIP, BOSTICH-BT1200, KOCAMAZ-KT 49, HAUBOLD : SKN16, DUO-FAST : HB 60, KIHBERG : 516, PASLODE : F16

Zimba Teli Staple	N25	N30	N35	N38	N40	N44	N50
Kutuda Adet Pcs / Box	5000	5000	2500	2500	2500	2500	2500
Kolide Adet Boxes/Carton	12	12	12	12	12	12	12

GAMA 25 PINS

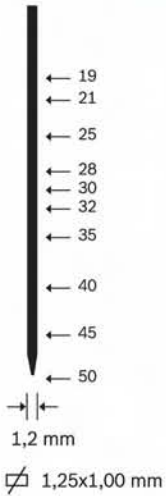

PREBENA 2 M-GA 32 SDS

FIELDS OF APPLICATION

- For invisible fastening
- Wooden, MDF, bamboo production
- Frames of mirrors, pictures, windows
- Floor covering
- To fix before gluing
- Flooring side works

- Fixing of decorative wooden panels
- In applications instead of nails
- Shoe manufacturing
- Stainless steel when needed

Available Materials: Electro galvanized, Stainless Steel (Inox)

Suitable With: PREBENA 2 M-GA 32 SDS, BEA-SK100, OMER-PINS, ATRO-I, BOSTICH: AZ5550, KOCAMAZ-KT 40

Zimba Teli Staple	G25/19	G25/21	G25/25	G25/28	G25/30
Kutuda Adet Pcs / Box	10000	5200	5000	5000	5000
Kolide Adet Boxes/Carton	30	50	30	30	30

82 SERIES PINS

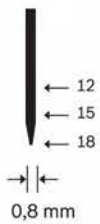

PREBENA

FIELDS OF APPLICATION

- For invisible fastening
- Wooden, MDF, bamboo production
- Frames of mirrors, pictures, windows
- Floor covering
- To fix before gluing

- Fixing of decorative wooden panels
- In applications instead of nails
- Stainless steel when needed

Available Materials: Electro galvanized, Stainless Steel (Inox)

Suitable With: PREBENA 1M-AL20, BEA-S717, OMER-R8.28, ATRO-MINI, BOSTICH: MINIPINS, KOCAMAZ-KT 18, KIHLEBERG : 506, HAUBOLD : ST06, SENCO : CZ

Zimba Teli Staple	B 82/15	B 82/18
Kutuda Adet Pcs / Box	7500	7500
Kolide Adet Boxes/Carton	80	80

Manufactured from AISI 304 & 316 stainless steel (inox) material.
 High quality raw material. Common use of stainless steel staples are:
 • Boat and yacht manufacturing • Fastening with Stainless Steel requirements

800 (80) SERIES

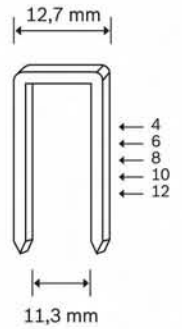

Ø 0,95x0,65 mm

FIELDS OF APPLICATION

- Upholstery works where stainless steel is needed
- Outdoor fastening and insulation works
- Automotive vinly interior fixing

Zimba Teli Staple	804PSZ	806PSZ	808PSZ	810PSZ	812PSZ	814PSZ
Kutuda Adet Pcs / Box	4500	4500	4500	4500	4500	3000
Kolide Adet Boxes/Carton	32	25	20	18	15	20

900 (92) SERIES

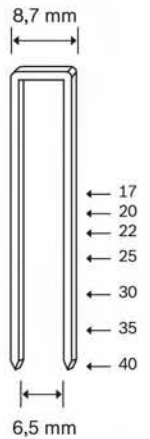

Ø 1,25x1,00 mm

Zimba Teli Staple	920 PSZ	925 PSZ
Kutuda Adet Pcs / Box	1000	900
Kolide Adet Boxes/Carton	48	20

FIELDS OF APPLICATION

- Pieces of woods called "strips" on wooden yachts and boats are fixed with Tipo Stainless 925mm to ensure durable and yachting compliant fastening. Pictures are actual examples of how this stripping process is made.



STAINLESS STEEL BRADS & PINS



J TYPE (F) BRADS

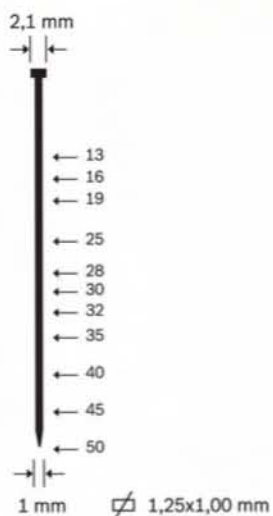

Manufactured from AISI 304 & 316 stainless steel (inox) material.

Common use of stainless steel brad and pins:

- Areas where nail is required and stainless steel feature is a must

82 SERIES PINS

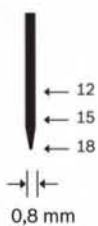

GAMA 25 PINS

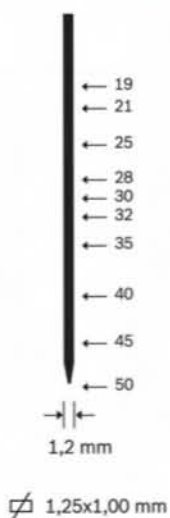

CHISEL & DIVERGENT POINT

FIELDS OF APPLICATION

- Chisel and divergent point staples make it harder to pull back, since the legs move inside the wood as shown in the illustrations

800 (80) SERIES

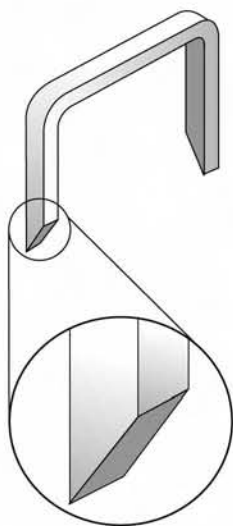

PREBENA 1M-A16-S30

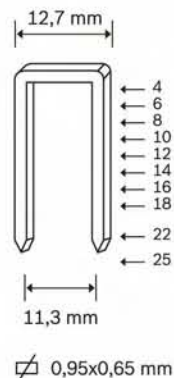

Zimba Teli Staple	804	805	806	808	810	812	814	816	818	822	825
Kutuda Adet Pcs / Box	4500	5000	5000	5000	4000	3000	3000	2750	2500	2000	1500
Kolide Adet Boxes/Carton	50	50	40	30	30	30	30	30	30	30	50

100 (93) SERIES



PREBENA 1M-025/SDS

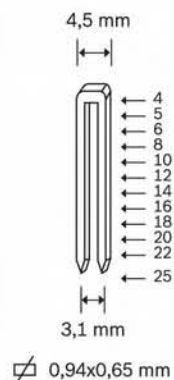

Zimba Teli Staple	104	106	107	108	110	112	114	116	118	120	122	125
Kutuda Adet Pcs / Box	8000	6000	4000	4000	4000	4000	2500	2500	2500	2000	2000	2000
Kolide Adet Boxes/Carton	80	80	80	80	75	65	80	80	70	80	75	65

400 (100) SERIES

tipo[®]

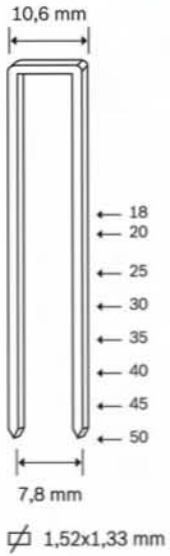

PREBENA 5X-L50



Zimba Teli Staple	420	425	430	435	440	450	455	460
Kutuda Adet Pcs / Box	675	600	525	450	375	300	2000	2000
Kolide Adet Boxes/Carton	36	36	36	36	36	36	14	14

900 (92) SERIES

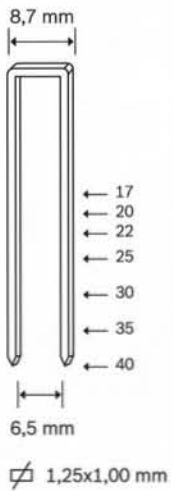

PREBENA 3M-H40



Zimba Teli Staple	917	920	922	925	930	935	940
Kutuda Adet Pcs / Box	2000	1080	900	900	720	540	600
Kolide Adet Boxes/Carton	50	36	66	36	36	36	36

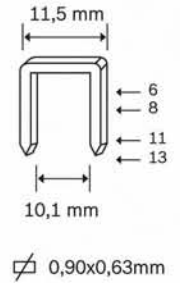

RO-MA H/72

FIELDS OF APPLICATION

- Carton bottom making
- Carton side stitching
- When staples are required to bend underneath

Available Materials: Copper coated

Zimba Teli Staple	5008	5011
Kutuda Adet Pcs / Box	3000	2200
Kolide Adet Boxes/Carton	100	100



5300 SERIES

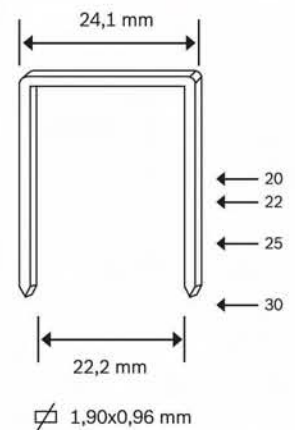

PREBENA

FIELDS OF APPLICATION

- Wood end to end fixing
- During packaging of hardwood to carton
- Roof covering
- Pallet making

Available Materials: Galvanized (Gold Color)

Zimba Teli Staple	5320	5322	5325
Kutuda Adet Pcs / Box	1680	1680	1680
Kolide Adet Boxes/Carton	15	15	14

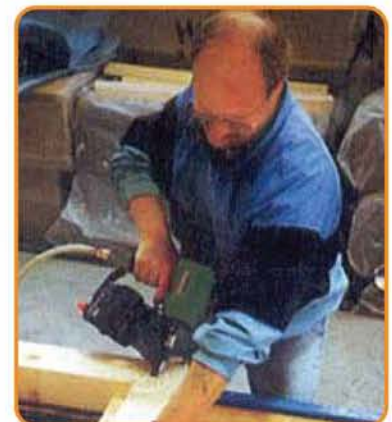

5400 SERIES

tipo[®]

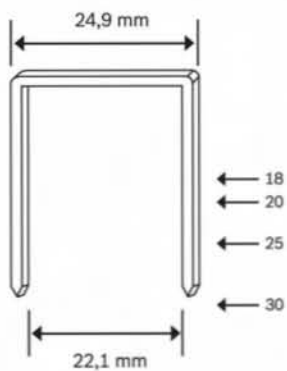

1,56x1,36 mm



PREBENA

FIELDS OF APPLICATION

- Wood end to end fixing
- During packaging of hardwood to carton
- Roof covering
- Pallet making

Available Materials: Galvanized (Gold Color)

Suitable With: BEA 140/38-153, OMER WC.38, OMER WS.38 RF

5500 SERIES

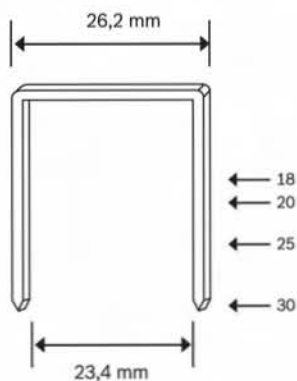

1,56x1,36 mm



PREBENA 5X-WS 38

FIELDS OF APPLICATION

- Wood end to end fixing
- During packaging of hardwood to carton
- Roof covering
- Pallet making

Available Materials: Galvanized (Gold Color)

Zimba Teli Staple	5519	5525
Kutuda Adet Pcs / Box	1720	860
Kolide Adet Boxes/Carton	22	30

24/6 OFFICE STAPLE

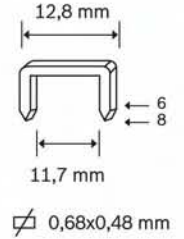

SACA HSP-13

FIELDS OF APPLICATION

- Light duty daily office use
- Up to ~35 pages
- Flowershops
- Paperbag stapling

Available Materials: Copper coated, electro galvanized

Zimba Teli Staple	24/6	24/6	24/6	24/8	24/8
Kutuda Adet Pcs / Box	1000	1000	1000	800	800
Kolide Adet Boxes/Carton	10	100	750	100	10

OMEGA (LOOP) STAPLES LOOP 24 SERIES

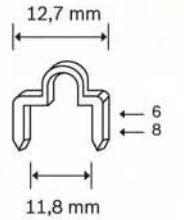

RING KING

FIELDS OF APPLICATION

- Brochure and catalogue
- For easy filing without punching

Available Materials: Electro galvanized



Zimba Teli Staple	24/6 ÇEN.	24/6 ÇEN.	24/8 ÇEN.	24/8 ÇEN.
Kutuda Adet Pcs / Box	1000	1000	1000	1000
Kolide Adet Boxes/Carton	100	10	100	10

LOOP 26 SERIES

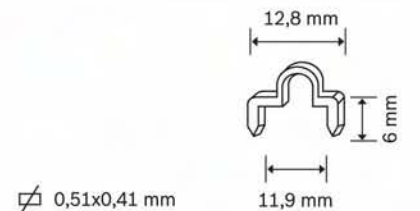

RING KING

Zimba Teli Staple	26/6 ÇEN.	26/6 ÇEN.
Kutuda Adet Pcs / Box	1200	1200
Kolide Adet Boxes/Carton	100	10

50 ENAK SERIES

tipo®

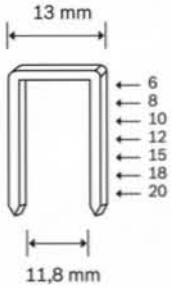

0,80x0,65 mm



FIELDS OF APPLICATION

- Printshops
- Booklet binding
- Stapling upto 200 pages
- Professional paper stapling needs

Available Materials: Electro galvanized, Steel

Suitable with: Enak & Kombinak staplers, suitable Nagel staplers

Zimba Teli Staple	50/6	50/8	50/10	50/12	50/15	50/18	50/20
Kutuda Adet Pcs / Box	5000	5000	5000	5000	5000	1000	1000
Kolide Adet Boxes/Carton	40	40	20	20	20	50	50

66 SERIES

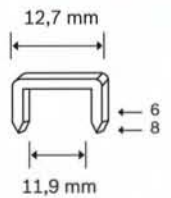

0,51x0,41 mm



FIELDS OF APPLICATION

- Printshops
- Booklet binding
- Electric operated staplers
- Professional paper stapling needs

Available Materials: Electro galvanized, Steel

Suitable with: Rapid Staplers

Zimba Teli Staple	66/6	66/8
Kutuda Adet Pcs / Box	5000	5000
Kolide Adet Boxes/Carton	48	36

NO:10

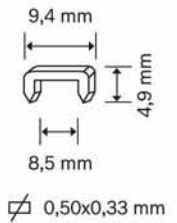

FIELDS OF APPLICATION

- Office and daily needs
- Stationary works

Zimba Teli Staple	10	10
Kutuda Adet Pcs / Box	1000	1000
Kolide Adet Boxes/Carton	50	1700

23 SERIES

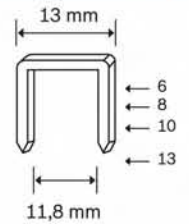

ETONA 75-100

FIELDS OF APPLICATION

- Printing and printshops
- Office needs
- Semi-professional needs

Zimba Teli Staple	23/6	23/8	23/10	23/13	23/15	23/17	23/20
Kutuda Adet Pcs / Box	900	1000	1000	1000	1000	1000	1000
Kolide Adet Boxes/Carton	100	100	100	100	50	50	50

NO:25

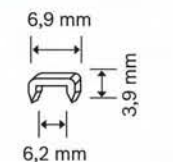

ROMEO PRIMULA 6

FIELDS OF APPLICATION

- Tiny staples keep out of sight
- Office and daily needs
- Stationary works

Zimba Teli Staple	25	25
Kutuda Adet Pcs / Box	2000	2000
Kolide Adet Boxes/Carton	50	500

26 SERIES



FIELDS OF APPLICATION

- Office and daily needs
- Stationary works

Zimba Teli Staple	26/6	26/8
Kutuda Adet Pcs / Box	1300	1000
Kolide Adet Boxes/Carton	100	100

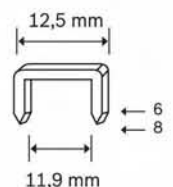

0,50x0,33 mm

FAST / EASY TO USE / DURABLE

VARIOUS FIELDS OF STEEL FIBER APPLICATION:

- Inner tunnel lining of mines and tunnels
- Slope stabilisation
- Retaining walls
- Repair works of tunnels
- Segmental parts of tunnel linings
- Sewer pipes
- Housing walls
- Wastewater tanks and rain water collectors
- Roof elements
- Railway sleepers, base-slabs
- Foundation blocks
- Channeling elements
- Impact resistance to concrete buildings
- Military safety cabins
- Concrete wave breakers
- Floorings of factories, warehouses etc.
- Airport taxi and landing areas
- Shipyard bases
- Many more...

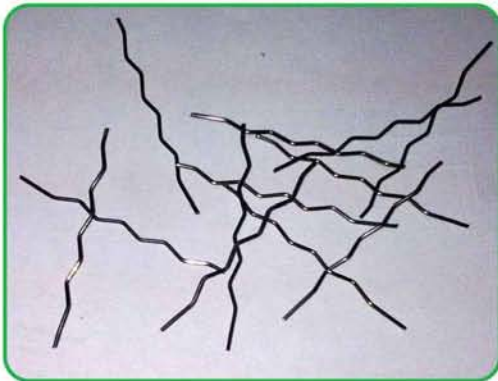
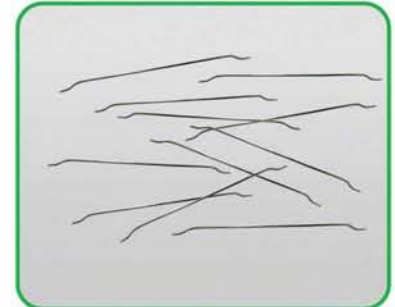

LOAD TEST

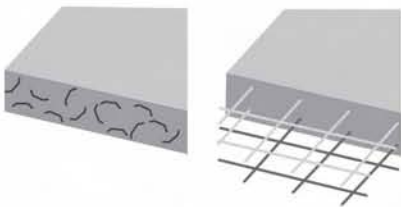
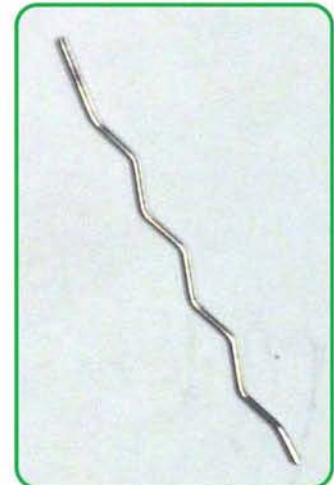
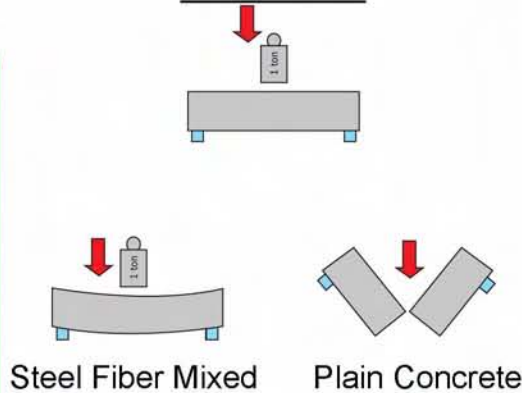

STEEL FIBER DIMENTIONS

TYPE	Hook End					Wave type	
Wire diameter (A)	0,80 - 0,90 - 1,00					0,80 - 0,90 - 1,00	
Length (B)	30	35	45	50	60	45	60
Packaging	20 kg						
Tensile	Min. 1100 N/mm ²						

ADVANTAGES OF STEEL FIBER

- Steel fibers are easy to use, they mix in the cement homogenously
- Wire mesh is hard to stock, and it requires measuring, cutting, welding before using
- The concrete is fragile by itself, steel fiber adds flexibility to plain concrete
- It can be used as traditionally, by shotcrete or with suitable dosing mixers
- Steel fibers can be used in wide area of usage for the steel fibers.



tipo®

TİPO TEL RAPTİYE SANAYİ VE TİCARET LTD. ŞTİ.

Akçay Caddesi No: 176 - 35410 Gaziemir / İZMİR

Tel: +90.232. 251 03 45 - 251 28 36 Fax: +90.232. 251 37 83

tipo@tipotel.com



ISO 9001:2008 QSM

Certificates the system